

*Air
Logic*®

Pneumatic Components and Systems



Accessories



Introduction to Air Logic

The Air Logic Division of Fred Knapp Engraving Company designs and manufactures a comprehensive line of pneumatic and vacuum control equipment – sensing and input elements, control elements, output interface devices and complete air supply systems. The control elements include both fluidic and moving diaphragm control components, each to be used where its own advantages are needed.

Air Logic is a manufacturer of various pneumatic accessories, ideal for instrumentation, medical and industrial applications.

The pneumatic accessories include Check Valves, Orifice Restrictors, Filtered Orifice Restrictors, Needle Valves, miniature Inline Filters and Preset Flow Controls.

The Check Valves feature miniature size, low cracking pressure and excellent repeatability.

The Orifice Restrictors are precision molded of polysulfone and are available in three models: 1) For inline installation, 2) Available with barbs for 1/16" or 1/8" I.D. flexible tubing or 3) Encased in a 10-32 barbed fitting.

The Filtered Orifice Restrictor contains an orifice restrictor and a stainless filter which are encased in the same housing. The filter is designed to remove most contaminate particles and protects the orifice restrictor.

The fine threads of the Needle Valve permit excellent adjustment for precise control of flow. Miniature size, sensitive adjustment and excellent repeatability are the features of Orifice Restrictors and Needle Valves.

The miniature Inline Filters are designed for a low pressure drop through the filter.

The Preset Flow Control maintains a constant flow in one direction and full flow in the opposite direction.

Air Logic manufactures a comprehensive and sophisticated line of pneumatic and vacuum components, with a strong reputation for immediate service, quality and dependability. For special applications and requirements, call Air Logic.

Air Logic and *A* are trademarks of Air Logic registered in the United States Patent and Trademark Office.

INDEX

Accessories	Page
Preset Flow Controls	1
Filters	2
Filtered Orifice Restrictors	2
Orifice Restrictors	3
Needle Valves.....	4-5
Check Valves	6

F-2804 Series Preset Flow Control



The Preset Flow Control maintains a constant flow in one direction and full flow in the opposite direction. The operation of the Flow Control is based on the movement of a small disc. The disc shifts within the housing as the pressure differential changes from forward to reverse. An orifice restrictor is encased in the center of the disc. A flat surface on one side of the disc seals and permits flow through the orifice.

The amount of flow permitted in the reverse direction, which is the sealing side, is determined by the orifice size. The amount of flow permitted in the forward direction is full flow.

- FEATURES**
- Precision Molded Orifice
 - Miniature Size
 - Minimum Cracking Pressure
 - Low Cost

SPECIFICATIONS

Maximum Supply: 75 PSI
 Operating Temperature: 40° to 120°F. (5° to 48°C.)
 Recommended Filtration: 5 micron
 Cracking Pressure: Less than 10" H₂O

MATERIALS

Orifice: Polysulfone
 Housing: Gray Polysulfone
 Disc: Silicone

MOUNTING

Inline

PORT CONNECTIONS

10-32 Threads, 10-32 Nipple is Supplied

ORDERING INFORMATION (Order by model number, specify orifice diameter and accessory letters required.)

F-2804-404 — **050** — **B85**

Model Number	Orifice Diameter	Port Connections
F-2804-404	041-0.004"	B80 - Barbs for 1/16" I.D. tubing B85 - Barbs for 1/8" I.D. tubing No accessory numbers required for 10-32 nipple
F-2804-404	050-0.005"	
F-2804-404	051-0.006"	
F-2804-404	071-0.007"	
F-2804-404	101-0.010"	
F-2804-404	121-0.012"	
F-2804-404	161-0.016"	
F-2804-404	201-0.020"	
F-2804-404	251-0.025"	
F-2804-404	301-0.030"	
F-2804-404	401-0.040"	

DIMENSIONS

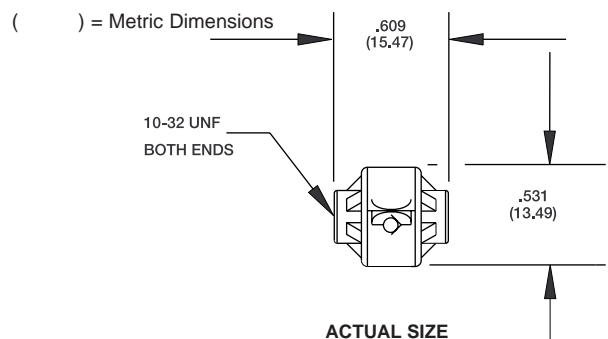

F-950, F-960, F-970 Series Filters



The Air Logic Filters are designed for compressed air systems to remove most contaminate particles.

Three models are available: 1) The F-950 Series is an inline filter with barbs for 1/16" or 1/8" I.D. tubing, 2) The F-960 Series filter is encased in a male 10-32 UNF threaded housing with barbs for 1/16" or 1/8" I.D. tubing, 3) The F-970 Series Filter is encased in a female 10-32 UNF threaded housing.

The filters are precision molded of polysulfone material. The Dutch weave wire screen is constructed of stainless steel. The Dutch weave is resistant to high pressure. The filters are available in 5, 25, 43 and 73 microns. Maximum supply is 125 PSI. The inline filter is disposable.

- FEATURES**
- Low Cost
 - Disposable
 - Small Size
 - Low Pressure Drop

SPECIFICATIONS
 Maximum Supply: 125 PSI
 Operating Temperature: 40° to 120°F. (5° to 48°C.)

MATERIALS
 Housing: Blue Polysulfone
 Filter Media: 316 stainless steel filter screen

MOUNTING
 Inline installation, 10-32 UNF male threads, or 10-32 UNF female threads

PORT CONNECTIONS
 Barbs for 1/16" or 1/8" I.D. flexible tubing
ORDERING INFORMATION (Order by model number, specify micron size, and port connection.)

Model Number	Mounting	Filter Size	Port Connection
F-950	Inline	5 - 5 micron 325 x 2300 mesh	B80 - Barbs for 1/16" I.D. tubing
F-960	Male 10-32 UNF	25 - 25 micron 200 x 600 mesh 43 - 43 micron 325 x 325 mesh	B85 - Barbs for 1/8" I.D. tubing
F-970	Female 10-32 UNF	73 - 73 micron 200 x 200 mesh	No accessory numbers required for 10-32 threads

DIMENSIONS

() = Metric Dimensions

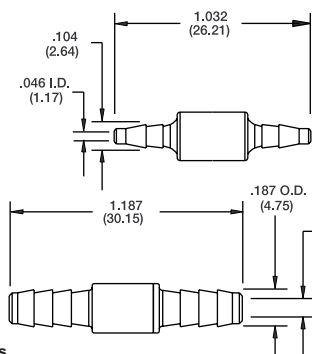

F-950 Series



F-960 Series

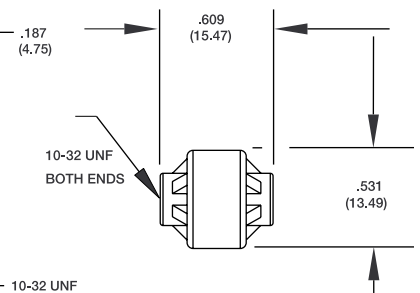
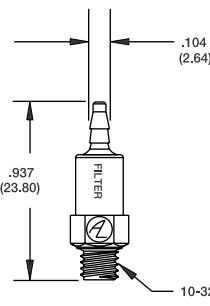

F-970 Series

F-950 Series Filtered Orifice Restrictors

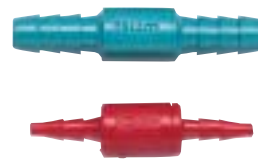

The Filtered Orifice Restrictors are designed for use in pneumatic control circuits. The orifice restrictor and a stainless steel filter are encased in a molded housing with barbs for 1/16" or 1/8" I.D. flexible tubing.

The Dutch weave wire screen is constructed of stainless steel. The filter is available in 5, 43 and 73 microns. The orifices are precision molded of polysulfone and are held to flow tolerances of ± 4%.

Available in ten color coded sizes .004" to .030" diameter. Maximum supply is 100 PSI. The Filtered Orifice Restrictors are disposable and designed for inline installation.

- FEATURES**
- Precision Molded
 - Miniature size
 - Low Pressure Drop

SPECIFICATIONS
 Orifice Diameter: .004" to .030"
 Maximum Supply: 100 PSI
 Operating Temperatures: 40° to 120°F. (5° to 48°C.)

MATERIALS
 Housing: Polysulfone
 Filter Media: 316 stainless steel filter screen

PORT CONNECTIONS
 Barbs for 1/16" or 1/8" I.D. flexible tubing

ORDERING INFORMATION (Order by model number, specify filter size, orifice diameter and accessory numbers for port connections.)

Model Number	Filter Size	Orifice Diameter	Color Code	Port Connection
F-950	5 - 5 micron 325 x 2300 mesh	.041-0.004"	Purple	B80 - Barbs for 1/16" I.D. tubing B85 - Barbs for 1/8" I.D. tubing
		.050-0.005"	Lime Green	
		.051-0.006"	Red	
	43 - 43 micron 325 x 325 mesh	.071-0.007"	Aqua Green	
		.101-0.010"	Yellow	
		.121-0.012"	Black	
		.161-0.016"	Gray	
	73 - 73 micron 200 x 200 mesh	.201-0.020"	Blue	
		.251-0.025"	Brown	
		.301-0.030"	Beige	

F-950 - 5 - 050 - B80

F-2815, F-3120 Series Orifice Restrictors



The Air Logic Orifice Restrictors are designed for use in pneumatic control circuits. Available in eleven color coded sizes.

The Orifices are precision molded of polysulfone and are held to flow tolerances of $\pm 4\%$.

The Orifice Restrictors are available in three models: 1) For inline installation, 2) Available with barbs for 1/16" or 1/8" I.D. flexible tubing, or 3) Encased in a 10-32 barbed fitting.

The F-2815 Series Orifice Restrictors are for inline installation with straight ports for 1/16" I.D. flexible tubing. The orifice restrictors are available with barbs for 1/16" or 1/8" I.D. flexible tubing.

The F-3120 Series Orifice Restrictors are encased in a molded polysulfone barbed fitting. The barbed fitting has 10-32 UNF male threads and is available with barbs for 1/16" or 1/8" I.D. flexible tubing.

ORDERING INFORMATION (Order by model number, orifice diameter and specify accessory numbers for port connections.)

Model Number		Orifice Diameter	Color Code	Port Connection
10-32 Threads	Inline			
F-3120	F-2815	041-0.004"	Purple	B80 - Barbs for 1/16" I.D. tubing B85 - Barbs for 1/8" I.D. tubing No accessory numbers required for straight ports.
F-3120	F-2815	050-0.005"	Lime Green	
F-3120	F-2815	051-0.006"	Red	
F-3120	F-2815	071-0.007"	Aqua Green	
F-3120	F-2815	101-0.010"	Yellow	
F-3120	F-2815	121-0.012"	Black	
F-3120	F-2815	161-0.016"	Gray	
F-3120	F-2815	201-0.020"	Blue	
F-3120	F-2815	251-0.025"	Brown	
F-3120	F-2815	301-0.030"	Beige	
F-3120	F-2815	401-0.040"	Rust	

DIMENSIONS

() = Metric Dimensions

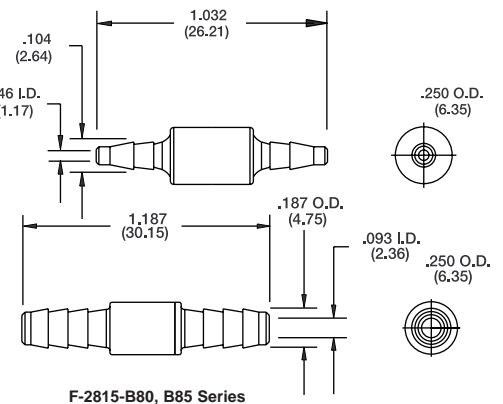
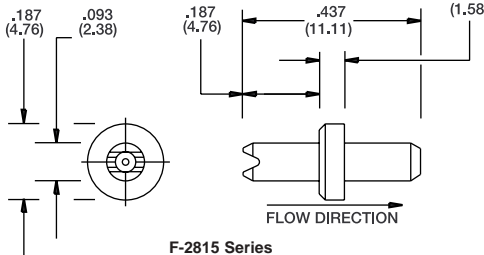
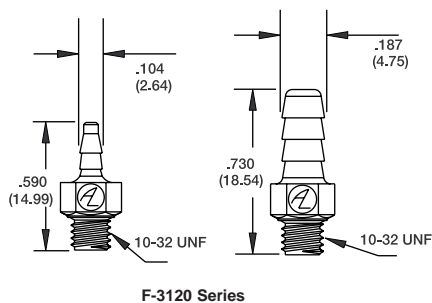

- ### FEATURES
- Precision Molded
 - Miniature size
 - Low Cost

SPECIFICATIONS

Orifice Diameter: .004" to .040"
 Maximum Supply: 100 PSI
 Operating Temperatures: 40° to 120°F. (5° to 48°C.)
 Recommended Filtration: 5 micron
 Flow Tolerances: $\pm 4\%$

MATERIALS

Housing: Polysulfone

MOUNTING

Inline installation or 10-32 UNF male threads

PORT CONNECTIONS

Straight ports for 1/16" I.D. flexible tubing
 Barbs for 1/16" or 1/8" I.D. flexible tubing

Typical Flow Characteristics for Normal Flow Direction

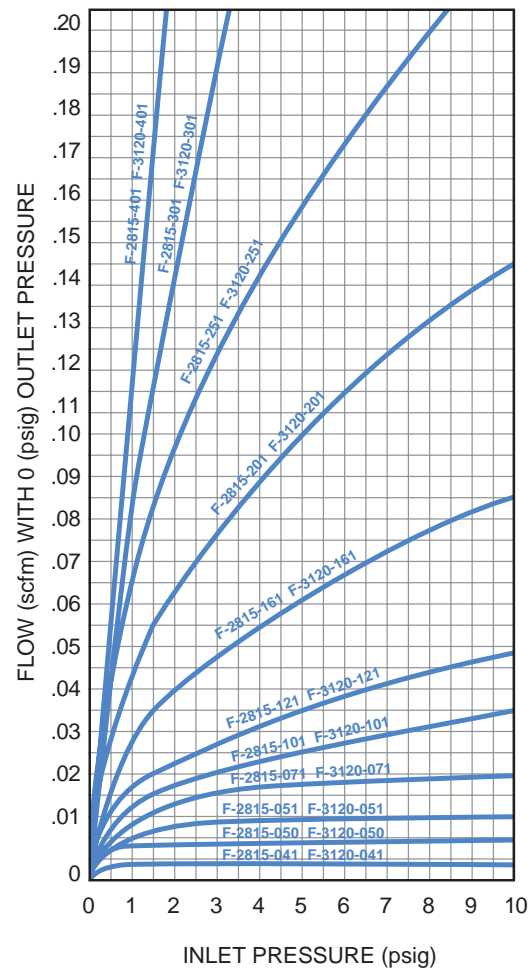

F-2822 Series Needle Valves

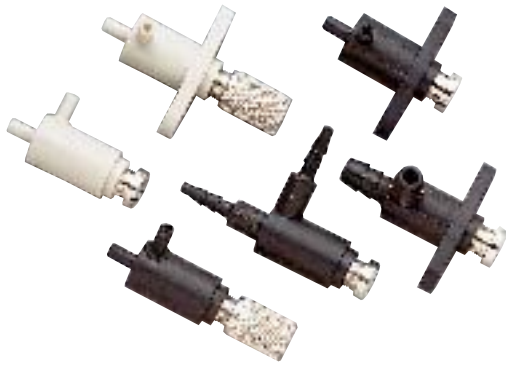

The F-2822 Series Needle Valves are ideal for instrumentation and industrial applications. The fine angle of the needle allows for the precise control of flow.

The Needle Valves are adjustable from 0 to the equivalent flow of a 0.025" diameter orifice. The flow is restricted in both directions. The Needle Valve is designed for inline installation or can be panel mounted. The standard device is furnished with a screwdriver slot adjustment or knurled knob.

The Needle Valves are available in two materials: Glass filled nylon or glass filled polypropylene. The o-rings are available in Buna-N, Viton or Ethylene Propylene.

ORDERING INFORMATION (Order by model number, mounting number, specify port connections and accessory letters.)

Type	Model Number	Mounting	Port Connections	Accessories
Nylon	F-2822	40-Inline	B80-Barbs for 1/16" I.D. Tubing B85-Barbs for 1/8" I.D. Tubing	K-Nickel plated brass adjustment knob SS-Stainless steel needle KSS-Stainless steel knob V-Viton o-ring E-Ethylene Propylene o-ring
		41-Panel Mounted	No accessory numbers required for straight ports	
Polypropylene	F-2822	50-Inline	Only available in straight ports	No accessory letters required for screwdriver slot adjustment or Buna-N o-ring
		51-Panel Mounted		

FEATURES

- Fine Adjustment
- Miniature Size
- Plastic Housing

SPECIFICATIONS

Turns: 7 turns
 Flow: Equivalent to 0.025" diameter orifice
 Adjustment Screw: Screwdriver slot or knurled knob
 Operating Temperature: 40° to 120°F. (5° to 48°C.)
 Recommended Filtration: 5 micron

MOUNTING

Inline installation or panel mounted. Furnished with two self tapping screws.

PORT CONNECTIONS

Straight ports for 1/16" I.D. flexible tubing
 Barbs for 1/16" or 1/8" I.D. flexible tubing

MATERIALS

O-ring: Buna-N, Viton, Ethylene Propylene (EPDM)
 Vibration Insert: None
 Body: F-2822-40 40% Glass Filled Nylon
 F-2822-41 40% Glass Filled Nylon
 F-2822-50 20% Glass Filled Polypropylene
 F-2822-51 20% Glass Filled Polypropylene
 Pin: Nickel Plated Brass or 303 Stainless Steel
 Pin Thread Size: 10-64
 Pin Angle: 6°

Typical Characteristics

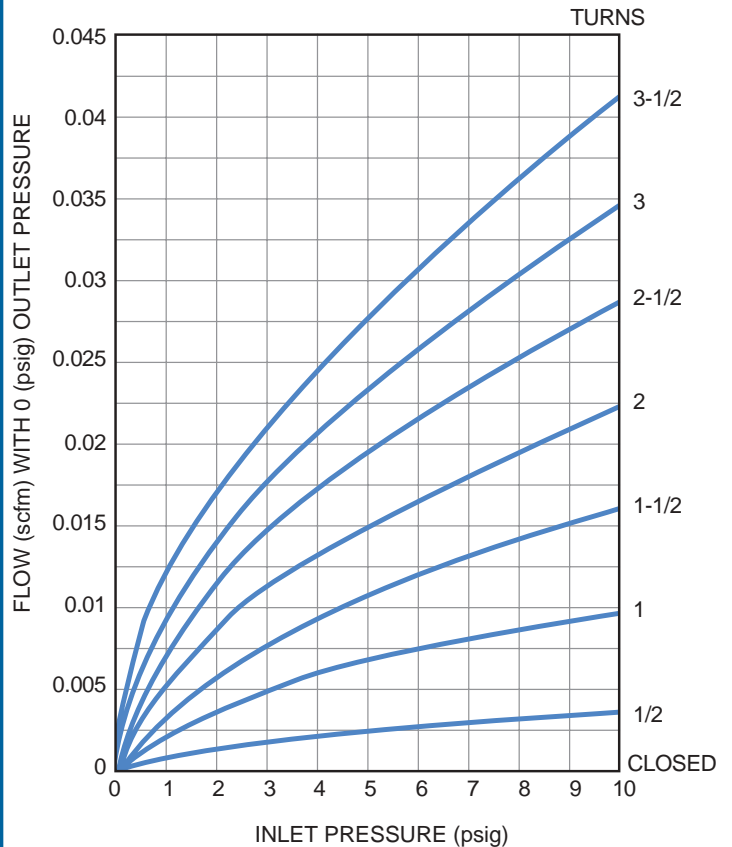

DIMENSIONS

() = Metric Dimensions

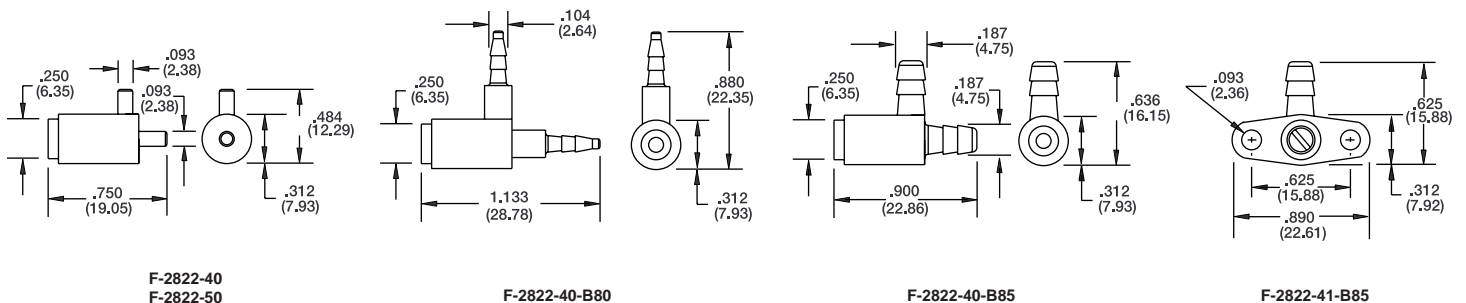

F-2822 Series Needle Valves



The F-2822 Series Needle Valves are ideal for instrumentation and industrial applications. The fine angle of the needle allows for the precise control of flow.

The Needle Valves are adjustable from 0 to the equivalent flow of a 0.025" diameter orifice. The flow is restricted in both directions. Two models are available from the standard units F-2822-20, 21 to the fine adjustment units F-2822-30, 31.

The Needle Valve is designed for inline installation or can be panel mounted. The standard device is furnished with a screwdriver slot adjustment.

ORDERING INFORMATION (Order by model number and specify accessory letters required.)

Type	Model Number	Mounting	Port Connections
Standard Model	F-2822-20	Inline	B80 - Barbs for 1/16" I.D. tubing B85 - Barbs for 1/8" I.D. tubing
	F-2822-21	Panel Mounted	
Fine Adjustment Model	F-2822-30	Inline	No accessory numbers required for straight ports
	F-2822-31	Panel Mounted	

MATERIALS

	F-2822-20 F-2822-21	F-2822-30 F-2822-31
O-ring	Buna N	Buna N
Vibration Insert	Nylon	Polyethylene
Body	Phosphor Bronze	Phosphor Bronze
Pin	Beryllium Copper	Beryllium Copper
Pin Thread Size	10-64	10-80
Pin Angle	6°	4°

DIMENSIONS

() = Metric Dimensions

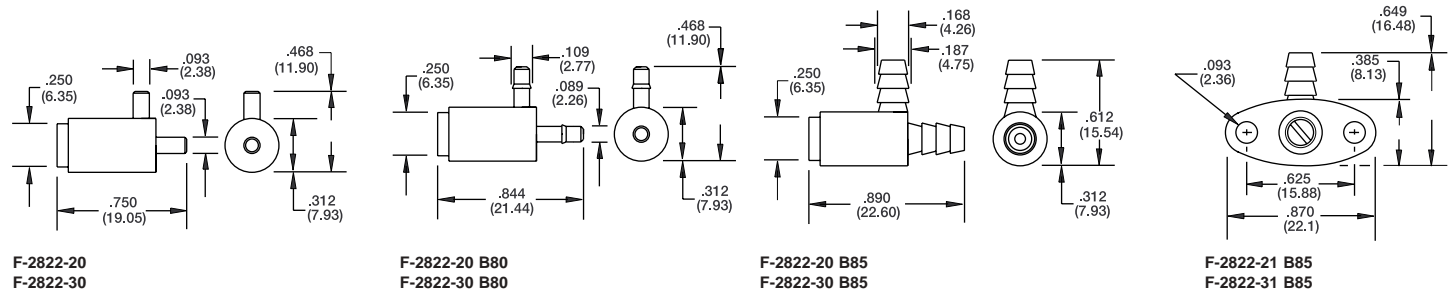

FEATURES

- Fine Adjustment
- Miniature Size
- Temperature Stable
- Minimum Drift

SPECIFICATIONS

Turns: 7 turns
 Flow: Equivalent to 0.025" diameter orifice
 Adjustment Screw: Screwdriver slot
 Operating Temperature: 40° to 120°F. (5° to 48°C.)
 Recommended Filtration: 5 micron
 Maximum Pressure: 100 PSI

MOUNTING

Inline installation or panel mounted. Furnished with two self tapping screws.

PORT CONNECTIONS

Straight ports for 1/16" I.D. flexible tubing
 Barbs for 1/16" or 1/8" I.D. flexible tubing

Typical Characteristics

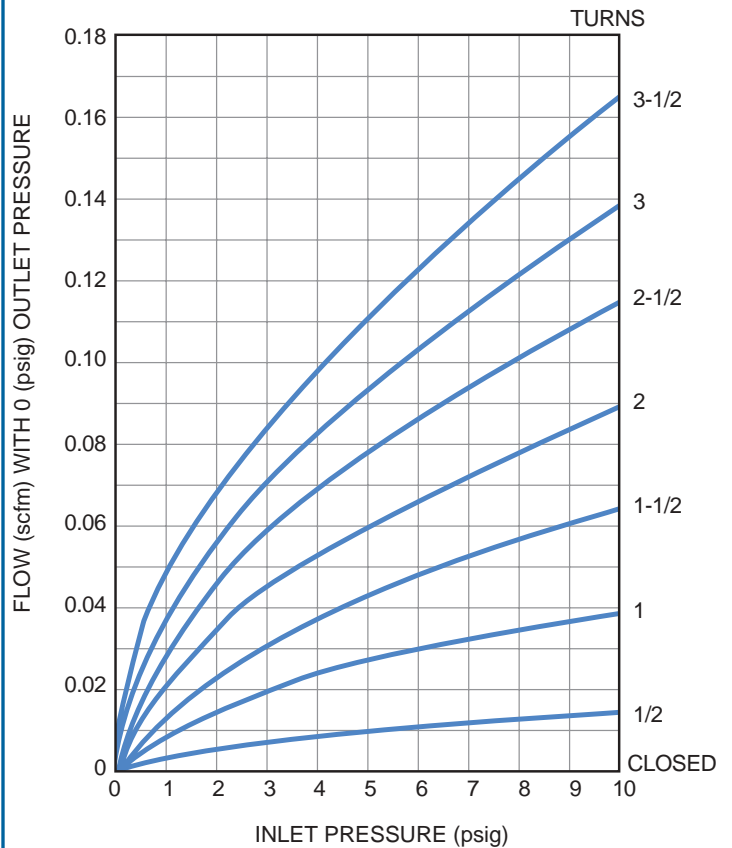

F-2804 Series Check Valves



The F-2804 Series Check Valves permit flow in one direction only. The operation of the check valve is based on the movement of a small disc. The disc shifts within the housing as the pressure differential changes from forward to reverse. A flat surface on one side of the disc seals off flow, while the other side allows flow to pass.

Five models are available: The Polypropylene Unit, F-2804-400, the Standard Units, F-2804-401, 402, and 403 and the High Flow Unit, F-2804-404.

The advantages of the check valve design are low "cracking pressure" and a minimum differential for forward flow, less than 0.005 PSI in the Standard Units. Secondly, there is no residual pressure difference across the check valve once flow has ceased. Flow in the forward direction is relatively unrestricted, approximately equivalent to the restriction of a 0.040 inch orifice in the Standard Units. The amount of flow permitted in the reverse direction, which is the sealing side, and the forward direction, which is full flow, is shown in the graphs below right.

ORDERING INFORMATION (Order by model number and specify accessory letters required.)

F-2804 - 404 - B85

Model Number	Color Code	Port Connection
F-2804-400	Red Symbol	Only available with 1/16" straight ports
F-2804-401	Orange Symbol	B80 - Barbs for 1/16" I.D. tubing B85 - Barbs for 1/8" I.D. tubing
F-2804-402	Green Symbol	
F-2804-403	Blue Symbol	No accessory numbers required for straight ports.
F-2804-404	Black Housing	B80 - Barbs for 1/16" I.D. tubing B85 - Barbs for 1/8" I.D. tubing No accessory numbers required for 10-32 threads.

FEATURES

- Minimum Cracking Pressure
- Miniature size
- Low Cost

SPECIFICATIONS

Maximum Supply: F-2804-400 • 10 PSI
F-2804-401 • 10 PSI
F-2804-402 • 10 PSI
F-2804-403 • 10 PSI
F-2804-404 • 75 PSI

Operating Temperature: 40° to 120°F. (5° to 48°C.)

Recommended Filtration: 5 micron

Cracking Pressure: F-2804-400 • Less than .8" H₂O
F-2804-401 • Less than .8" H₂O
F-2804-402 • Less than .8" H₂O
F-2804-403 • Less than .8" H₂O
F-2804-404 • Less than 10" H₂O

MATERIALS

	Housing	Disc
F-2804-400	• Polypropylene	• Silicone
F-2804-401	• Polysulfone	• Celcon
F-2804-402	• Polysulfone	• Celcon
F-2804-403	• Polysulfone	• Silicone
F-2804-404	• Polysulfone	• Silicone

MOUNTING

Inline

PORT CONNECTIONS

Straight ports for 1/16" I.D. flexible tubing

Barbs for 1/16" or 1/8" I.D. flexible tubing

The F-2804-404 has 10-32 threads

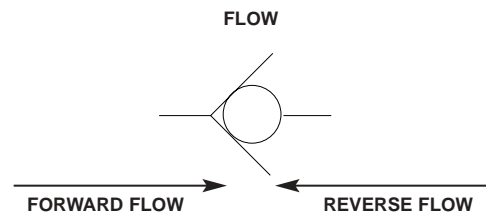

TYPICAL FLOW CHARACTERISTICS

Model Number	Reverse Flow @ 1 PSI Differential	Forward Flow @ 1 PSI Differential
F-2804-400	Less than 0.20 SCIM	0.12 SCFM 1 PSI Supply
F-2804-401	Less than 2.98 SCIM	
F-2804-402	Less than 1.00 SCIM	
F-2804-403	Less than 0.20 SCIM	2.0 SCFM 75 PSI Supply
F-2804-404	Less than 0.06 SCIM	

DIMENSIONS

() = Metric Dimensions

